

Dear customer,

Congratulations!

You have chosen the best product we know how to make with our 30 years of experience and passion for precision.

Please follow the instructions in this manual to avoid mistakes and save time.

In case you need further information or you have further requests we will be glad to be at your disposal.

With best regards,

Your GRIP GmbH

GRIP GmbH Handhabungstechnik
Alter Hellweg 70
44379 Dortmund, Germany

Tel. +49 231 96450 01

info@grip-gmbh.com
www.grip-gmbh.com



SHS Connector

	Contents	Page
1	General	2
2	Description of function	2
3	Safety	3
	3.1 Symbolism of safety instructions	3
	3.2 Intended use	3
	3.3 Environmental and operating conditions	3
	3.4 Modification of the supported product	3
	3.5 Safety instructions	4
4	Warranty	5
5	Technical data	5
6	Scope of delivery	5
7	Transportation	5
8	Commissioning	6
	8.1 Assembly	6
	8.2 Additional items	7
9	Maintenance and care	9
	9.1 Disassembly	9
	9.2 Torque specifications	9
10	Disposal	10
11	Components	10
	11.1 Product overview	10
	11.2 Exploded view	11
12	Parts list	11
	12.1 Accessories, spare and wear parts	12
13	EC-Declaration of incorporation	13

1 General



IMPORTANT

Read thoroughly before use.
Keep for future reference.

Applicable documents:

The technical data sheets mentioned in chapter 5 apply in addition to this document.

All documents, 2D drawings and 3D models can be downloaded at
www.grip-gmbh.com/en/downloads/verbinden/.

Scope of application:

These instructions apply to all sizes of the SHS Connector.

2 Description of function

The SHS Connector serves as a manual quick-change system for quickly replacing components on the robot arm. To open the change system, pull the locking pin on the hand lever. As a result, the thrust bolt is displaced radially and releases the force-locked crimp connection in the bore of the lower assembly. The upper and lower assembly can now be pulled apart. (s. image 1-3).

Integrated pneumatic feedthroughs automatically couple during the joining process. By these ducts the air gets directed through the changing system to the tool.

Image 1



Image 2



Image 3



3 Safety

3.1 Symbolism of safety instructions

**DANGER!**

Safety notes with this signal word warn of an imminently hazardous situation that could result in death or serious injury.

**WARNING!**

Safety notes with this signal word warn of a potentially hazardous situation that could result in death or serious injury.

**CAUTION!**

Safety notes with this signal word warn of a possible hazardous situation that could result in minor or moderate injury.

**NOTICE!**

Safety notes with this signal word warn of a possible hazardous situation that can lead to material or environmental damage.

3.2 Intended use

- The SHS Connector has been designed as an interface between the handling device and the tool (e.g. gripper). The upper assembly is mounted on the robot. The lower assembly is mounted on the end effector.
- Furthermore, the SHS can also be used in special solutions, automation and also as a general mechanical standard interface.
- The unit may only be used within the scope of its technical data.
- The pneumatic feed-throughs are intended exclusively for use with air and vacuum.
- The system is intended for the installation in a machine. The requirements of the applicable instructions must be considered and adhered to.

3.3 Environmental and operating conditions

Use this unit only in dry and splash-proof environments at room temperature as well as within the application parameters defined in the technical specifications. If this is not the case, warranty cannot be accepted. Exceptions are units designed especially for the respective conditions.

3.4 Modification of the supported product

Unauthorized modifications to the product in the form of structural changes can lead to impairment of safety, function and the loss of warranty claims.

3.5 Safety instructions

Dangers may arise from the unit, if:

- the product is not installed or inserted properly,
- the system is not used for its intended purpose,
- the safety and installation notes are not observed.

Everyone who is responsible for assembly, commissioning and maintenance must read and understand the complete operating instructions. Improper use, which affects the function and operational safety of the SHS Connector, is prohibited.

**CAUTION!****Risk of injury from falling objects!**

In order to prevent damage to the connector as well as injuries to the operator, the lower assembly or the tool must be secured by hand or other devices before opening the change system. Otherwise there is a risk that irreparable damages to the tool or injury to the operator are caused by the unit falling down.

**CAUTION!**

The locking pin (Img. 12, item 6) is used to secure the lock of the system. When the lock is engaged, the pin must be inserted into the radial bore of the upper part (Img. 12, item 1). After operating the hand lever, it is essential to check that the pin is correctly engaged!

**CAUTION!****Risk of injury due to contact with lubricants!**

Contact with lubricants can cause allergies and skin irritation. Wear protective gloves when handling lubricants. After unintentional eye contact, rinse lubricant thoroughly with plenty of water and seek medical attention if necessary.

**CAUTION!****Risk of injury from ejected particles!**

Before unlocking the system, the energy transfer (power, vacuum, air pressure) to the tool must be switched off and any residual currents, air pressure, vacuum, etc. in the system must be eliminated. Failure to observe this can lead to hardware damage or injury.

**NOTICE!**

The unit may only be operated if the machine in which the unit is installed complies with the relevant provisions of the machinery directive 2006-42-EC.

4 Warranty

If the product is used as intended in 1-shift operation the warranty is valid for 24 months from the ex-works delivery date under observance the mandatory maintenance and lubrication intervals and the given operating conditions. Generally parts touching the work piece and wear parts are not part of the warranty. Wear parts are listed in chapter 12.1. The unit is considered to be defective if its basic function "Lock" is no longer functioning.

5 Technical data

Behold technical data sheets: TD-SHS050-EN, TD-SHS063-EN, TD-SHS080-EN, TD-SHS100-EN, TD-SHS125-EN, TD-SHS160-EN

6 Scope of delivery

- Product as shown in Image 11 depending on the order number

The scope of delivery can be found in the order confirmation. The weights and dimensions can be found in the technical data sheets.

- Check the entire delivery for completeness using the enclosed delivery documents.
- Report any damage caused by defective packaging or transportation to the forwarding agent and GRIP GmbH immediately after the incoming goods inspection.

7 Transportation



WARNING!

Risk of injury from falling objects!

Inadequate transport and storage securing may result in serious injury and damage to property if the product falls.

- Secure the product against tipping, slipping and falling during transportation and storage.

Storage and transportation conditions:

- Dry and splash-proof environment
- Temperature range from -30 °C to +120 °C.

8 Commissioning

8.1 Assembly



CAUTION!

Risk of injury due to unexpected movements!

Only perform installation work when the power supply is switched off!



CAUTION!

Risk of crushing fingers when closing the SHS!

When assembling and locking the system, make sure that no parts of the skin get caught in the locking joints.

The upper assembly of the SHS Connector is mounted on the robot flange, the manipulator or similar actuators. It can be centered using a centering disc. The angular orientation is determined by a fitting hole.

The lower assembly is mounted on grippers, measuring devices or other tools. For this purpose, there are through-holes for screws in the lower assembly as well as internal threads for screwing directly into the lower assembly (see Image 4).

If the change systems cannot be mounted directly, adapter flanges must be used. Use screws according to DIN 912 or ISO 4762 for installation. The screw-in depths of the screws must be observed. We recommend the use of "medium-strength" screw locking.

All sizes have a fitting hole for angular alignment. The mounting surfaces comply with ISO 9409-1.

Image 4

Mounting variants on the lower assembly (example size 063)

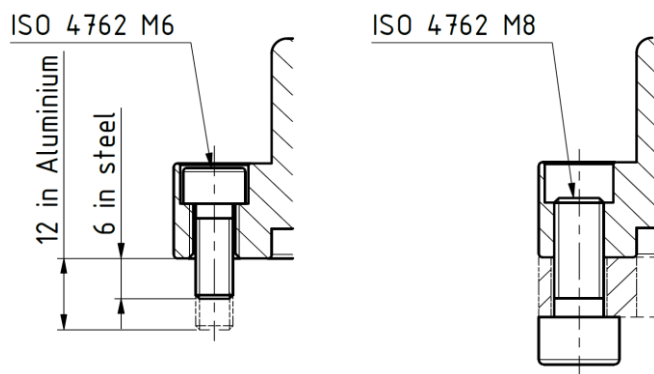

8.2 Additional items

We offer various additional items to extend the functions of the SHS Connector. A clear overview of all accessories can be found in chapter 11 (11.1 Product overview; Image 11). For order numbers, see 12.1 Accessories, spare and wear parts.

Pneumatic flange

Depending on the size, several radial and axial pneumatic connections can be connected to the upper and lower assembly for pneumatic feed-through.

Due to the hand lever, only half of the existing pneumatic feed-throughs on the upper assembly can be used radially. If all feed-throughs need to be used radially, an optional pneumatic flange can be used. This is mounted between the upper assembly and the robot and routes the existing axial feed-throughs on the side of the hand lever to radial outlets (see Image 5).

Image 5

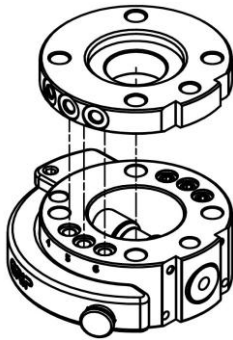

SEK adapter

As an option, the SHS can be equipped with an energy coupling (SEK) using an adapter plate. The SEK enables the simultaneous coupling of electrical feed-throughs. It is mounted to the adapter plates with two cylinder head screws, and the adapter plates are mounted in the same way to the upper and lower assembly (see Image 6 and 7). For further installation instructions, please refer to the SEK installation and operating instructions.

Image 6

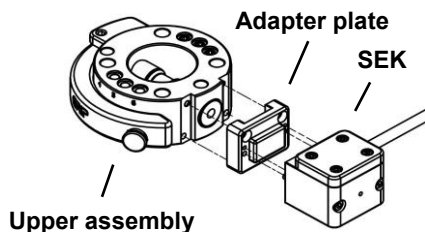
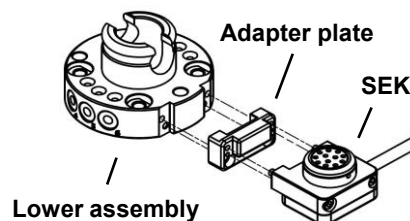

Image 7



Centering disc

In order to achieve a precise fit, we offer a corresponding centering disc as an additional item for each size (see Image 8).

The use of a centering disc ensures that the upper assembly and/or lower assembly of the Connector are properly centered. Installation on both the upper assembly and lower assembly is possible (as shown in image 9).

Image 8**Image 9****Thread inserts**

As already explained and illustrated in section 8.1 Assembly, the lower assembly has threads in the through-holes of the mounting surface for direct screw attachment. In some cases, smaller threads are required to mount the tool, especially for the lower sizes. For this reason, we offer threaded inserts for sizes 050, 063 and 080.

These are inserted into the counterbores and offer the option of using screws with M6 threads for mounting (see Image 10).

Image 10

9 Maintenance and care

The SHS is virtually maintenance-free. The thrust bolt must be checked for functionality at regular intervals. The mating surfaces and moving parts must be kept clean and lightly greased.

- Every change:
 - Carry out a visual inspection; in the case of soiling, clean and re-grease surfaces
- Every 200 changes:
 - Clean all components thoroughly
 - Re-grease the spring locking pin and all mating contact surfaces of the upper and lower assembly
- Lubricant used and recommended (manufacturer):
 - Klübersynth UH1 14-151 (Klüber Lubrication München GmbH & Co. KG)
 - Synthetic lubricating grease for the food and pharmaceutical industry



NOTICE!

Specific information on the lubricant used can be found in the product information and the lubricant manufacturer's safety data sheet.

9.1 Disassembly

(See chapter 11.2 Exploded view; Image 12)

1. Disassemble the SHS.
2. If applicable, shut off and remove compressed air lines.
3. Loosen the cylinder screws for the holder (pos. 4).
4. Remove the assembly holder (pos. 4) with components (pos. 2, 3, 5, 6, 9 and 10), loosen the guide screws (pos 7 and 11).
5. To disassemble thrust bolt (pos. 2) from the other components (pos. 3, 5 and 6), remove cylinder pins (pos. 9 and 10).
6. Clean all parts thoroughly. Inspect for wear and defects.
7. Lubricate all mating surfaces.

9.2 Torque specifications

M6 – 8,5 Nm; M8 – 20,6 Nm; M10 – 41 Nm; M12 – 71 Nm

10 Disposal



NOTICE!

Dispose of assemblies properly!
Improper disposal of assemblies can cause environmental damage and be prosecuted!

Dispose of the components in accordance with local regulations. Ensure that the environmentally friendly disposal of operating supplies. The local regulations for proper waste recycling and disposal must be observed.

The product consists of:

- Aluminium (base body, hand lever, holder)
- Steel (thrust bolt, locking bolts, pins, screws, connecting elements)
- NBR (seals)

11 Components

11.1 Product overview

Image 11

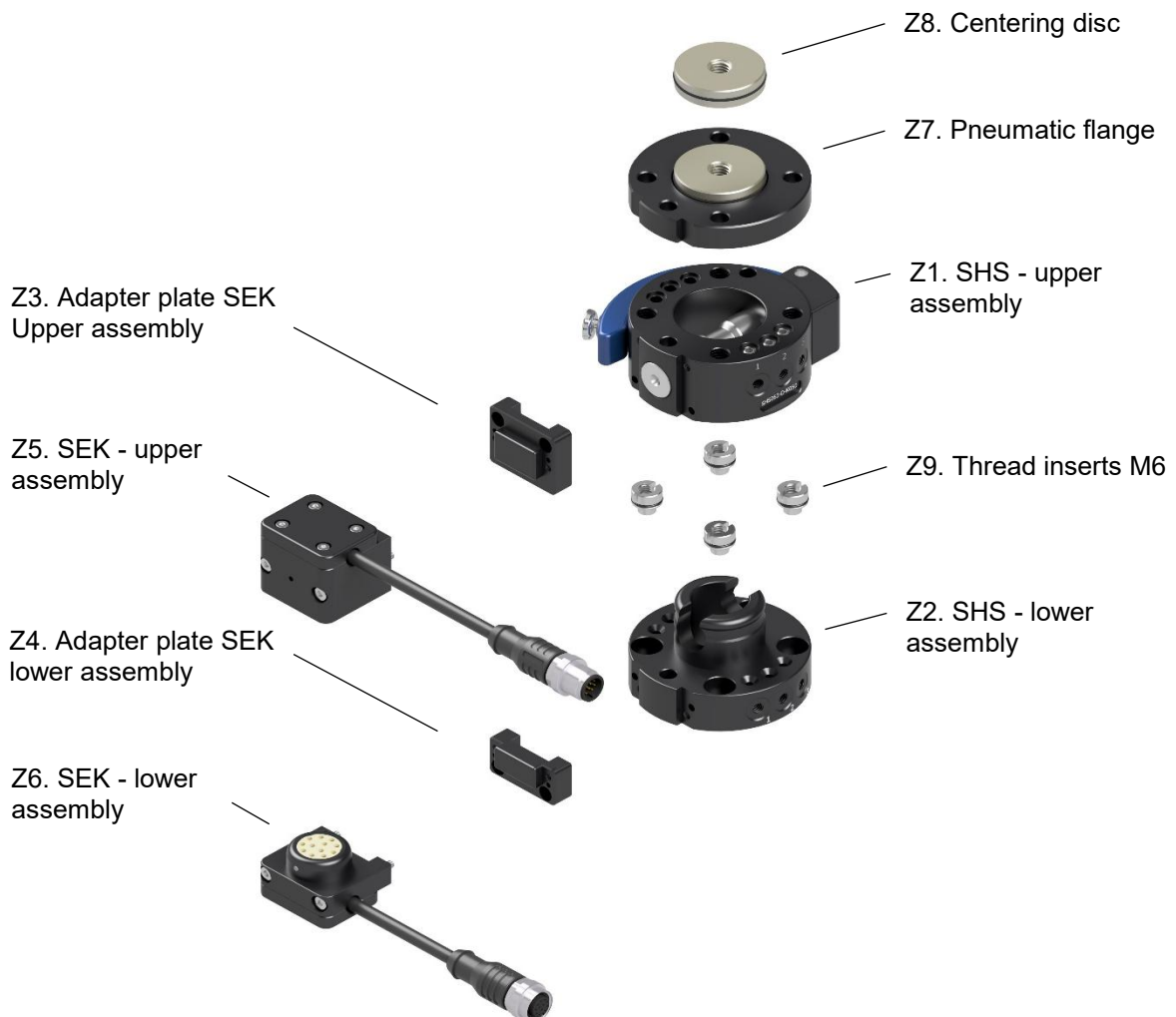

11.2 Exploded view

Image 12

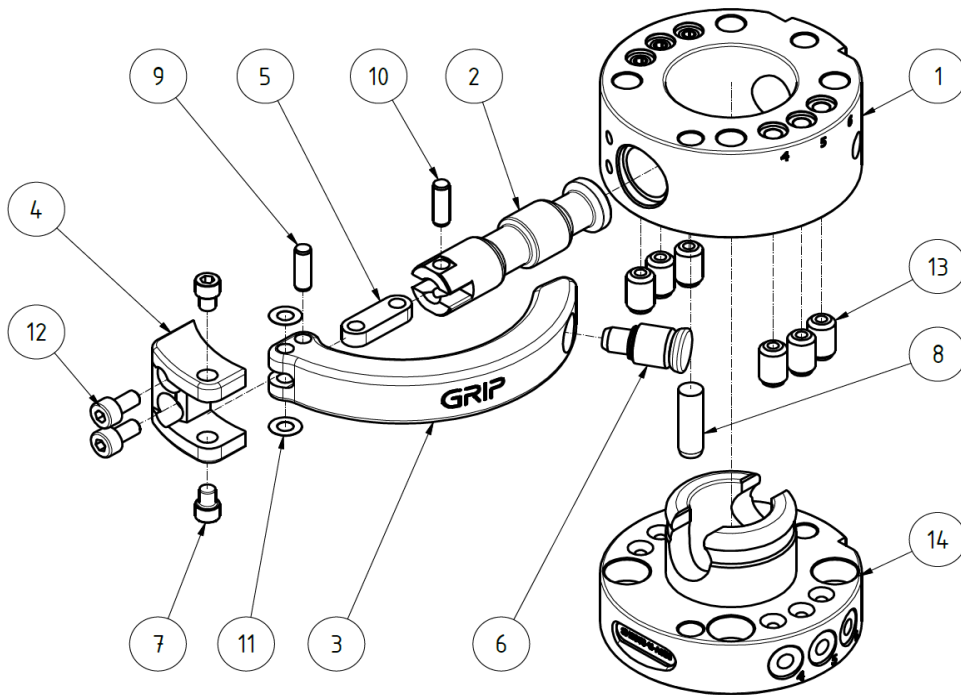

12 Parts list

Pos.	Description	Quantity
1	Upper assembly	1
2	Thrust bolt	1
3	Hand lever	1
4	Holder	1
5	Lug	1
6	Spring locking pin	1
7	Guiding screw	2
8	Index pin	1
9	Cylinder pin lug	1
10	Cylinder pin thrust bolt	1
11	Shim ring	2
12	Cylinder screw	2
13	Pneumatic seal	4-12*
14	Lower assembly	1

*The number of seals depends on the size.

12.1 Accessories, spare and wear parts

Pos.	Description	Order-Nr.	Quantity
Z1	SHS Connector upper assembly	G-SHS...-O-K...	1
Z2	SHS Connector lower assembly	G-SHS...-U-A...	1
Z3	Adapter plate SEK upper assembly	ZG-AP-SEK100-SHS...-O	1
Z4	Adapter plate SEK lower assembly	ZG-AP-SEK100-SHS...-U	1
Z5	SEK energy coupling upper assembly	G-SEK100-O-1E12-300-M12	1
Z6	SEK energy coupling lower assembly	G-SEK100-U-1E12-300-M12	1
Z7	Pneumatic flange incl. Centering disc	G-ZS...-S...P	1
Z8	Centering disc	G-ZS...-1	1
Z9	Thread insert M6	ZG-GE-M6	4
2	Thrust bolt	EG-SHW...-QB	1
3	Hand lever	EG-SHW...-HH	1
4	Holder	EG-SHW...-HA	1
6	Spring locking pin (SHS050)	EG-MGW050-RB	1
6	Spring locking pin (SHS063-160)	EG-MGW063-160-RB	1
13	Pneumatic seal kit	EG-SHS...-PD	4-12

