

Operating mode:

The double-acting cylinder is operated via pneum. compressed air and actuates the power unit. By two angularly arranged springs, which engage in the grooves of the bolts, the vertical is converted into horizontal movement.

Advantages:

- High life span
- Two stroke variants stroke 1 or stroke 2
- Mechanical interface according to DIN EN ISO 9409-12
- Low dead weight
- Optional gripping force safety device "opening" via pressure spring (7)
- Optional gripping force safety device "closing" via pressure spring (7)
- Depending on the mounting, gripping force safety device "closing" or "opening"
- Universal jaws (15) for easy mounting of specific fingers
- Piston position detection optionally via proximity switch ZG-RSGU01-300-M8



Technical specifications			GP100	
Gripping force at 6 bar	F_G [N]	stroke 1	opening	3200
			shutting	2800
		stroke 2	opening	1600
			shutting	1400
Gripping force factor	f_g [N/bar]	stroke 1	opening	530
			shutting	466
		stroke 2	opening	265
			shutting	233
Gripping force safety device	F_S [N]	stroke 1	min.	770
			max.	1500
		stroke 2	min.	385
			max.	750
System stroke per jaw	h [mm]	stroke 1	6	
		stroke 2	12	
Rec. component weight (stroke 1)	m_w [kg]	14*		
Rec. component weight (stroke 2)	m_w [kg]	28*		
Weight gripper	m_g [kg]	1,9		
Operating pressure (with gripping force safety device)		5 ...6 bar		
Operating pressure (w/o gripping force safety device)		2 ...6 bar		
Air consumption per stroke	V [ccm]	38,6		
Air connection	$P_{max} = 10$ bar	G 1/8		
Mounting flange	ISO	4 x M8 on Ø80		
Operating temperature range [°C]		-30 to +120		
* This guideline applies to the following assumptions: force-locking, static friction coefficient: 0,2, operating pressure: 6 bar, double safety				

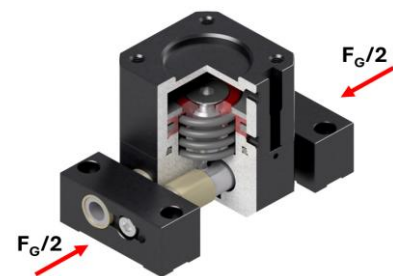

Parallel gripper Ø100...

G-GP100-I1-GÖ	ISO-flange, stroke 1 gripping force safety device opening
G-GP100-I1-GS	ISO-flange, stroke 1 gripping force safety device shutting
G-GP100-I1-O	ISO-flange, stroke 1 without gripping force safety device
G-GP100-I2-GÖ	ISO-flange, stroke 2 gripping force safety device opening
G-GP100-I2-GS	ISO-flange, stroke 2 gripping force safety device shutting
G-GP100-I2-O	ISO-flange, stroke 2 without gripping force safety device

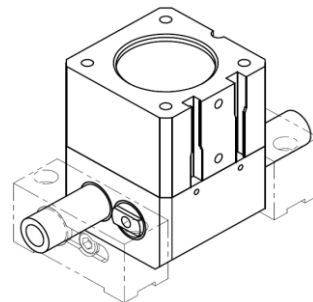

Equipment GP

ZG-GP100-UB	Universal jaw for GP100 pair
ZG-RSGU-01	Signal transmitter with LED
ZG-RSGU01-300-M8	Signal transmitter with LED, with M8 plug

Spare parts GG

EG-GG100-DS	Gasket set for gripper size 100
-------------	---------------------------------

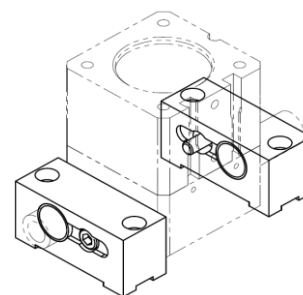

Pos.	Description
1	Cylinder ISO
4	Magnetic ring
6	Cone
7	Compression spring
8	Power unit 1/2
11	Housing
13	Plain bearing bushing housing
14	Bolt 1/2
15	Universal jaw
16	Plain bearing bushing UB
17	Cylinder head screw UB

