

Dear customer,

Congratulations!

You have chosen the best product we know how to make with our 30 years of experience and passion for precision.

Please follow the instructions in this manual to avoid mistakes and save time.

In case you need further information or you have further requests we will be glad to be at your disposal.

With best regards,

Your GRIP GmbH

GRIP GmbH Handhabungstechnik
Alter Hellweg 70
44379 Dortmund, Germany

Tel. +49 231 96450 01

info@grip-gmbh.com
www.grip-gmbh.com



SHW Connector

	Contents	Page
1	Operation	2
2	Safety	2
	2.1 Symbol	2
	2.2 Intended use	2
	2.3 Environmental and operating conditions	2
	2.4 Safety indication	2
3	Warranty	3
4	Scope of delivery	3
5	Technical data	3
6	Assembly	3
7	Maintenance and care	4
	7.1 Disassembly	4
	7.2 Torque specifications	4
8	Parts list	5
	8.1 Spare and wear parts	5
9	Exploded view	6
10	EC-Declaration of incorporation	7

1 Operation

To open the change system, pull the locking pin on the hand lever. As a result, the crossway bolt is displaced radially and releases the force-locked crimp connection in the bore of the lower assembly. The upper and lower assembly can now be pulled apart.

2 Safety

2.1 Symbol



This symbol indicates possible hazards to persons or the SHW Connector.

2.2 Intended purpose

The SHW Connector has been designed as an interface between handling device and tool (e.g. gripper). Furthermore, the SHW can also be used in special solutions, automation and also as a general mechanical standard interface. The unit may only be used in the context of its technical specifications. The system is intended for the installation in a machine. The requirements of the applicable instructions must be considered and adhered to.

2.3 Environmental and operating conditions

Use this unit only in dry and splash-proof environments at room temperature as well as within the application parameters defined in the technical specifications. If this is not the case, warranty cannot be accepted. Exceptions are units designed especially for the respective conditions.

2.4 Safety indication

Dangers may arise from the unit, if:

- the product is not installed or inserted properly,
- the system is not used for its intended purpose,
- the safety and installation notes are not observed.

Everyone who is responsible for assembly, commissioning and maintenance must read and understand the complete operating instructions. Improper use, which affects the function and operational safety of the SHW Connector, is prohibited.



CAUTION! Never operate the hand lever when the load is suspended!

In order to prevent damage to the connector as well as injuries to the operator, the lower assembly or the tool must be secured by hand or other devices before opening the change system. Otherwise there is a risk that irreparable damages to the tool or injury to the operator are caused by the unit falling down.



NOTICE!

The unit may only be operated if the machine in which the unit is installed complies with the relevant provisions of the machinery directive 2006-42-EC.

3 Warranty

If the product is used as intended in 1-shift operation the warranty is valid for 24 months from the ex-works delivery date under observance the mandatory maintenance and lubrication intervals and the given operating conditions. Generally parts touching the work piece and wear parts are not part of the warranty. Wear parts are listed in chapter 8.1. The unit is considered to be defective if its basic function "Lock" is no longer functioning.

4 Scope of Delivery

- SHW as shown in Image 7 depending on the order number of the upper or lower assembly.

5 Technical Data

Behold technical data sheets: TD-SHW050-EN, TD-SHW063-EN, TD-SHW080-EN, TD-SHW100-EN, TD-SHW125-EN, TD-SHW160-EN

6 Assembly

The upper assembly of the SHW Connector is mounted on the robot flange, the manipulator or similar actuators. It can be centered with the help of a centering disc. The angular orientation is determined by means of a fitting bore. The lower assembly is mounted on grippers, measuring instruments or other tools. If the SHW Connector can not be installed directly, adapter flanges must be used. Use screws according to DIN 912 or ISO 4762. The screw-in depth of the screws must be observed. We recommend the use of a "medium-tight" screw lock.

For axial adjustment all sizes provide a fitting bore. This bore is designed according to ISO 9409.

Optionally, the SHW can be provided with a SEK energy feed-through. The SEK enables the simultaneous coupling of electrical lines. The SEK is mounted with two cylinder screws to the upper and lower assemblies. For further installation instructions, please refer to the assembly and operating instructions of the SEK.



CAUTION!

Perform assembly work only when the power supply is switched off!



CAUTION! Risk of pinching the fingers when closing the SHW

When closing the connector ensure fingers are not between the upper and lower assembly.



CAUTION! The locking pin (Img. 6, item 6) is used to secure the lock of the system. When the lock is engaged, the pin must be inserted into the radial bore of the upper part (Img. 6, item 1). After operating the hand lever, it is essential to check that the pin is correctly engaged!

Image 1



Image 2



Image 3



Centering disc

In order to achieve a precise fit, centering discs in every size are offered (as shown in image 3).

The use of a centering disc ensures that the upper assembly and/or lower assembly of the Connector are properly centered. Installation on both the upper assembly and lower assembly is possible (as shown in image 4).

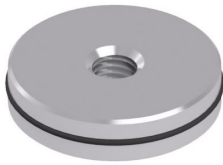
Image 4**Image 5**

7 Maintenance and care

The SHW is virtually maintenance-free. Check the semi-cylindrical bolt in regular intervals for correct function. Keep the mating surface and the moving parts clean and lubricate them slightly.

Spare parts and component parts of the SHW can be found on our homepage:

7.1 Disassembly of the SHW

(Behold Image 6)

1. Disassemble the SHW.
2. If applicable shut off and remove compressed air lines.
3. Loosen the cylinder bolts for the holder (pos. 4).
4. Remove the assembly holder (pos. 4) with components (pos. 2, 3, 5, 6, 9 and 10), loosen the guide screws (pos 7 and 11).
5. To disassemble crossway bolt (pos. 2) from the other components (pos. 3, 5 and 6), remove cylinder pins (pos. 9 and 10).
6. Clean all parts thoroughly. Inspect for wear and defects.
7. Lubricate all fitting surfaces.

For assembly, reverse the order.

7.2 Torque specifications

M6 – 8,5 Nm; M8 – 20,6 Nm; M10 – 41 Nm; M12 – 71 Nm

8 Parts list

Pos.	Description	Quantity
1	Upper assembly	1
2	Crossway bolt	1
3	Hand lever	1
4	Holder	1
5	Strap pin	1
6	Spring locking pin	1
7	Guiding screw	2
8	Index pin	1
9	Cylinder bolt BL	1
10	Cylinder bolt QB	1
11	Shim ring	2
12	Lower assembly	1

8.1 Spare and wear parts, depending on size

Pos.	Description	Order-No.
2	Crossway bolt	EG-SHW...-QB
3	Hand lever	EG-SHW...-HH

9 Exploded view

Image 6

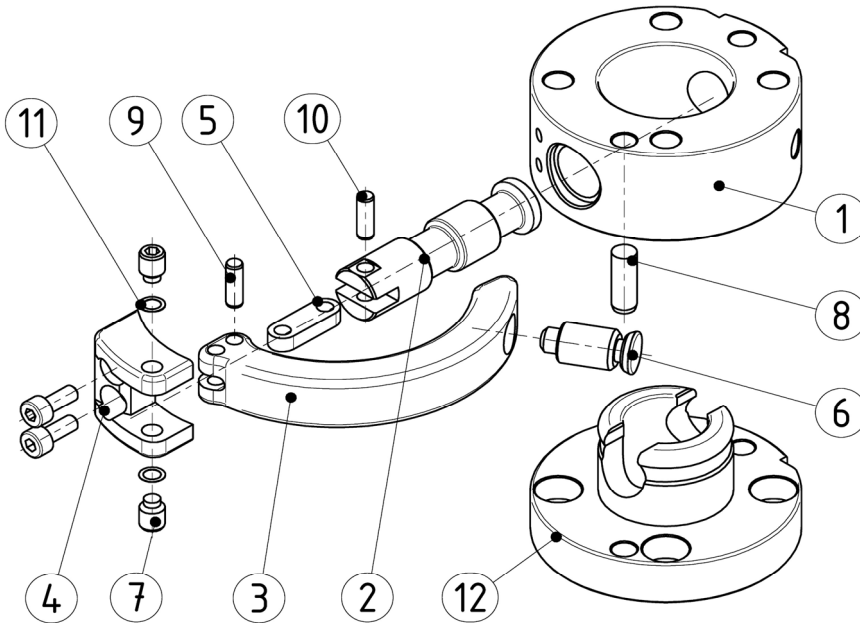

Image 7



Upper assembly

Lower assembly

10 EC - Declaration of incorporation

according to the Machinery Directive 2006/42/EC, annex II B

The producer / distributor GRIP GmbH Handhabungstechnik
Alter Hellweg 70
D-44379 Dortmund, Germany

hereby declares that the following products

Product designation: Thrust lever change system (SHW)

Functional description: Systems for the manual and form-closed exchange of components such as grippers and tools on robots or receptacles

Type designation: G-SHW050, 063, 080, 100, 125, 160

The provisions of the above-mentioned directives -including their effective amendments- comply with the time of the declaration.

He further states that the following essential requirements of the Machinery Directive 2006/42/EC were applied and observed:
annex I, numerics: 1.1.2; 1.1.3; 1.1.5; 1.3.2; 1.7.4

He further states that the specific technical documentation has been drawn up in accordance with annex VII, Part B.

The following harmonized standard has been applied:

EN ISO 12100:2010 Safety of Machinery- Basic concepts, general principles for design- Part 1:
Basic terminology and methodology

Safety of Machinery- Basic concepts, general principles for design- Part 2:
Technical principles

In the case of reasoned requests, the specific documents shall be sent to the national authorities as follows: Post

The product mentioned above may only be put into operation if it has been established applicable that the unit, into which the above-mentioned product is to be incorporated, complies with the provisions of the Machinery Directive 2006/42 / EC.

Authorized representative: Dipl.-Ing. (FH) Hasan Canti

Location: Dortmund
Date: 29.10.2025



Dipl.-Ing. (FH) Hasan Canti
Executive Director