

GRIP: G-SHS063  
 Oberteil: G-SHS063-O-K050  
 Unterteil: G-SHS063-U-A050

S: SHS050  
 Kopf: SHK-050-000-000  
 Adapter: SHA-050-000-000

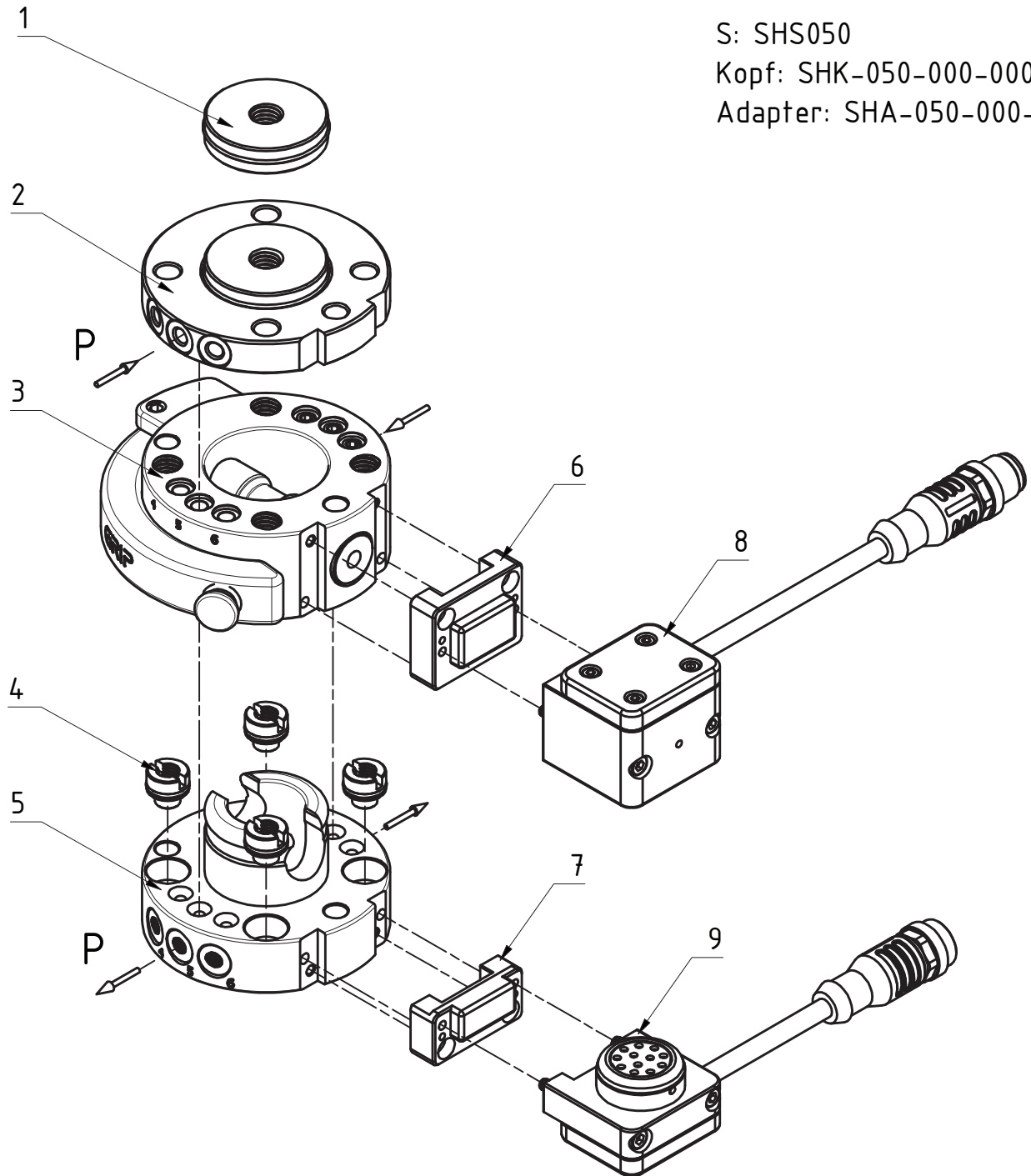

Pos.	GRIP Art.-Nr.	Beschreibung
1	G-ZS063-1	Zentrierscheibe, Al, eloxiert
2	G-ZS063-S3P	Pneumatikflansch inkl. G-ZS063-1
3	G-SHS063-O-K050	Oberteil, Kopf, TK=50
4	ZG-GE-M6	Gewindeinsatz M6, VA (50, 63, 80)
5	G-SHS063-U-A050	Unterteil, Adapter, TK=50
6	ZG-AP-SEK100-SHS063-O	Adapterplatte, Oberteil, für SEK100
7	ZG-AP-SEK100-SHS063-U	Adapterplatte, Unterteil, für SEK100
8	G-SEK100-O-1E12-300-M12	SEK100 Oberteil
9	G-SEK100-U-1E12-300-M12	SEK100 Unterteil

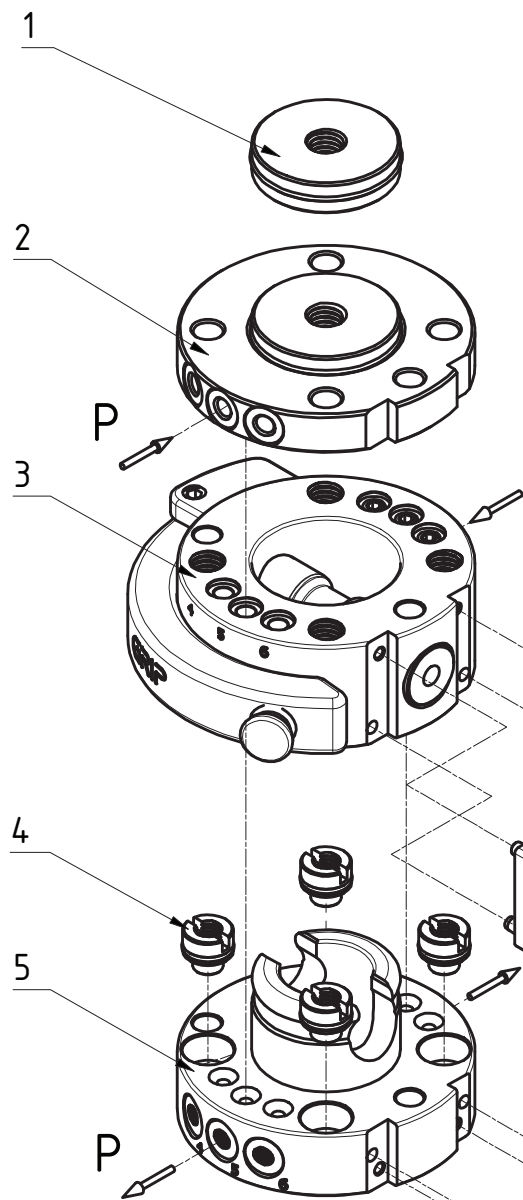

GRIP: G-SHS063  
 Oberteil: G-SHS063-O-K050  
 Unterteil: G-SHS063-U-A050

S: SHS050  
 Kopf: SHK-050-000-000  
 Adapter: SHA-050-000-000

Elektromodule beispielhaft;  
 diverse Varianten verfügbar

Pos.	GRIP Art.-Nr.	Beschreibung	S Art.-Nr.	S ID
1	G-ZS063-1	Zentrierscheibe, Al, eloxiert	A-HWK-050-BOSS	0302752
2	G-ZS063-S3P	Pneumatikflansch inkl. G-ZS063-1	A-SHK-050-P-RADIAL	1391557
3	G-SHS063-O-K050	Oberteil, Kopf, TK=50	SHK-050-000-000	0310410
4	ZG-GE-M6	Gewindeeinsatz M6, VA (50, 63, 80)		
5	G-SHS063-U-A050	Unterteil, Adapter, TK=50	SHA-050-000-000	0310411
6	ZG-SHS063-O-K050-S7	Adapterplatte K050-S7	SHK-050-AKO-S7	1304734
7	ZG-SHS063-U-A050-S7	Adapterplatte A050-S7	SHA-050-AKO-S7	1304738
8	ZG-SHS063-O-K050-S5	Adapterplatte K050-S5	SHK-050-AKO-S5	1304699
9	ZG-SHS063-U-A050-S5	Adapterplatte A050-S5	SHA-050-AKO-S5	1304710
10	G-SWO-A15-K	A15 Elektromodul, Kopf	SWO-A15-K	9936357
11	G-SWO-A15-A	A15 Elektromodul, Adapter	SWO-A15-A	9936356
12	G-SWO-EM8-005-K	M8-005 Elektromodul, Kopf	SWO-EM8-005-K	9966150
13	G-SWO-EM8-005-A	M8-005 Elektromodul, Adapter	SWO-EM8-005-A	9966151

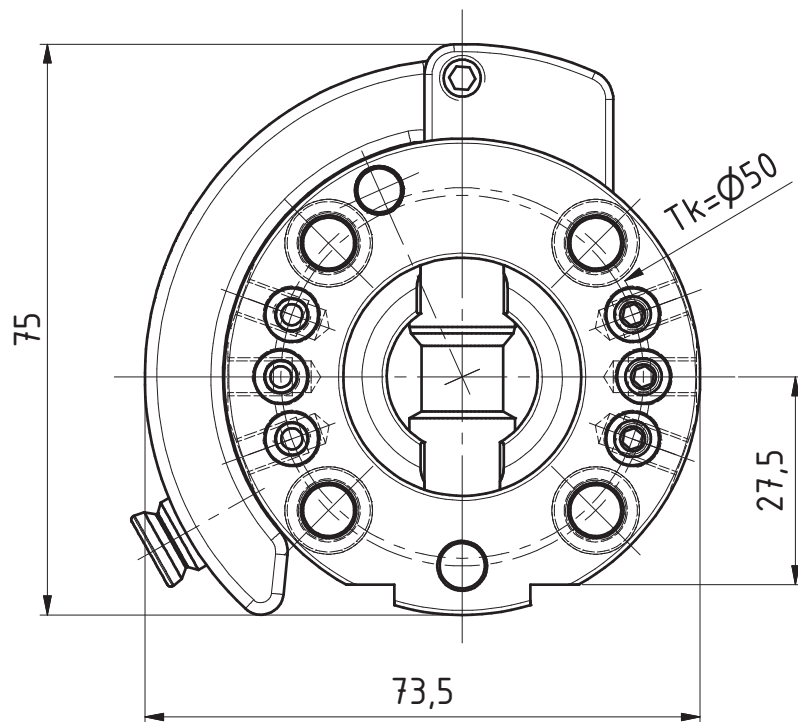
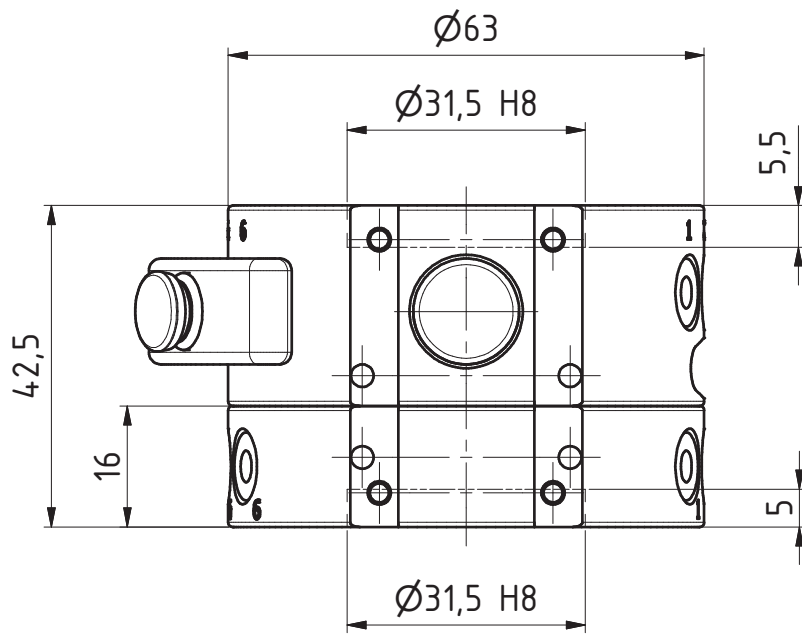

( 1 : 2 )

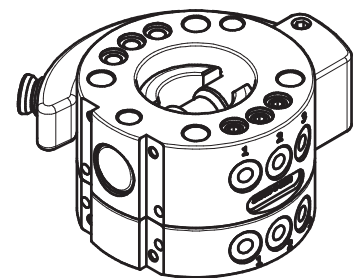

Datum 17.04.2024

Maßstab 1:1

Zeichnungsnummer

G-SHS063-2ZEP

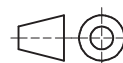

**GRIP**

GRIP GmbH Handhabungstechnik

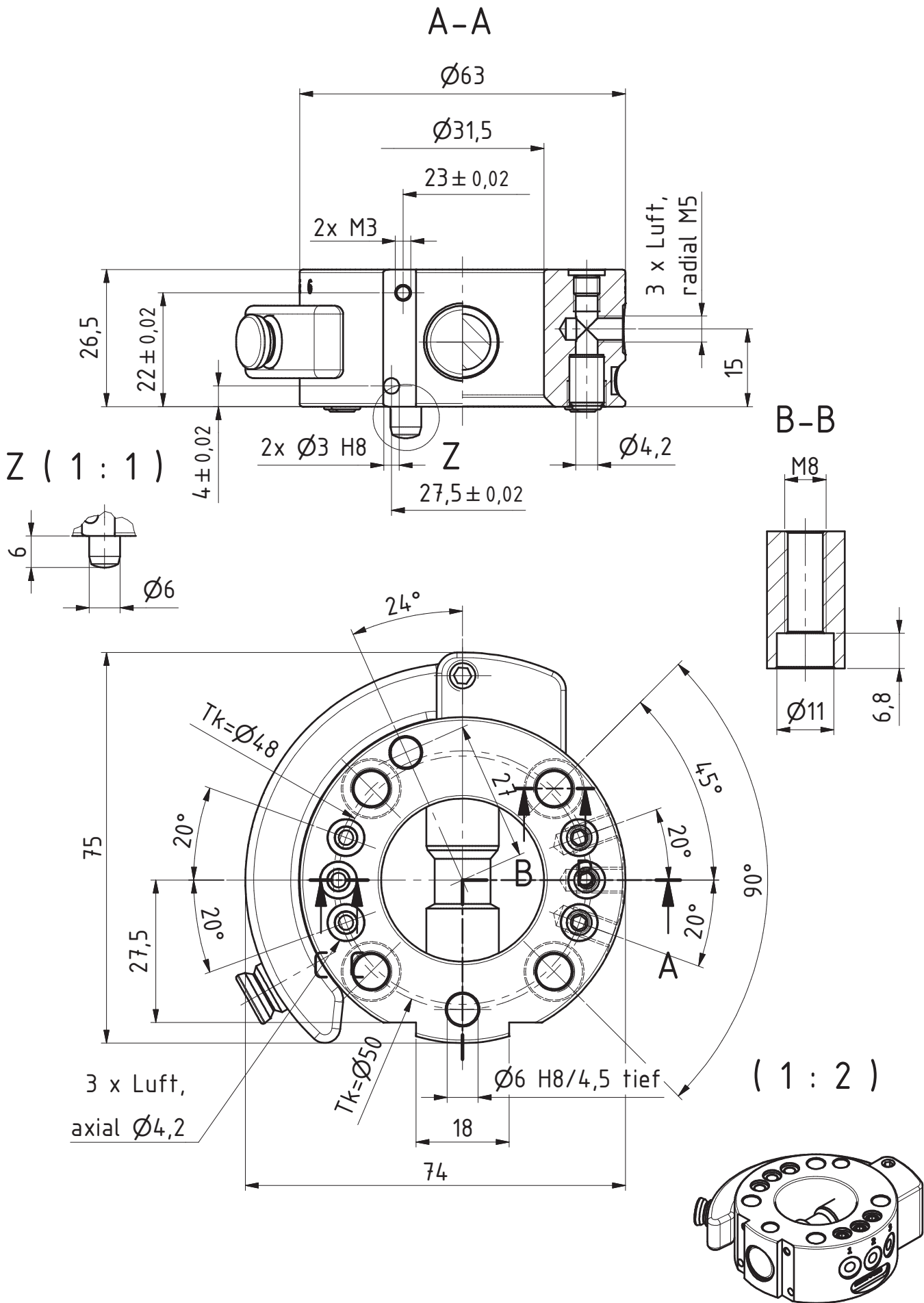

Datum 17.04.2024

Maßstab 1:1

Zeichnungsnummer

G-SHS063-0-K050

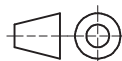

**GRIP**  
GRIP GmbH Handhabungstechnik

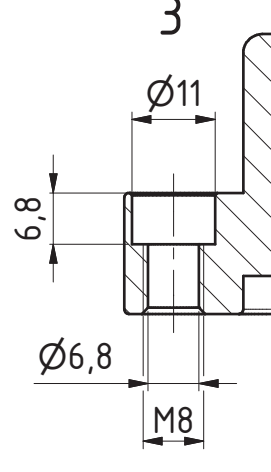
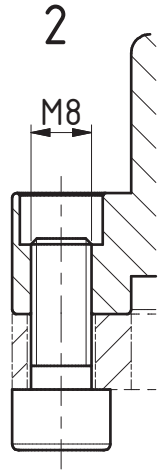
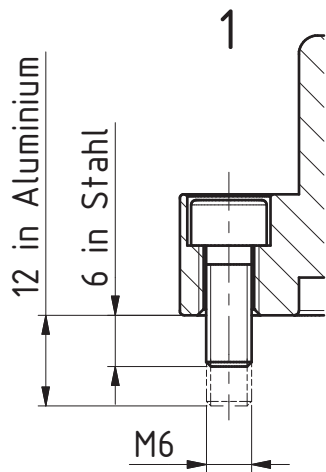
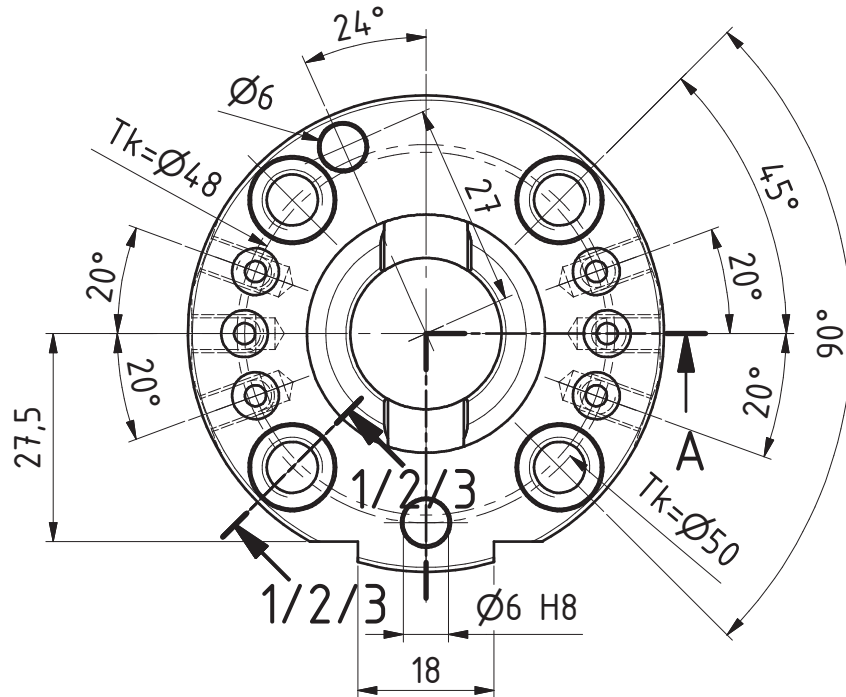
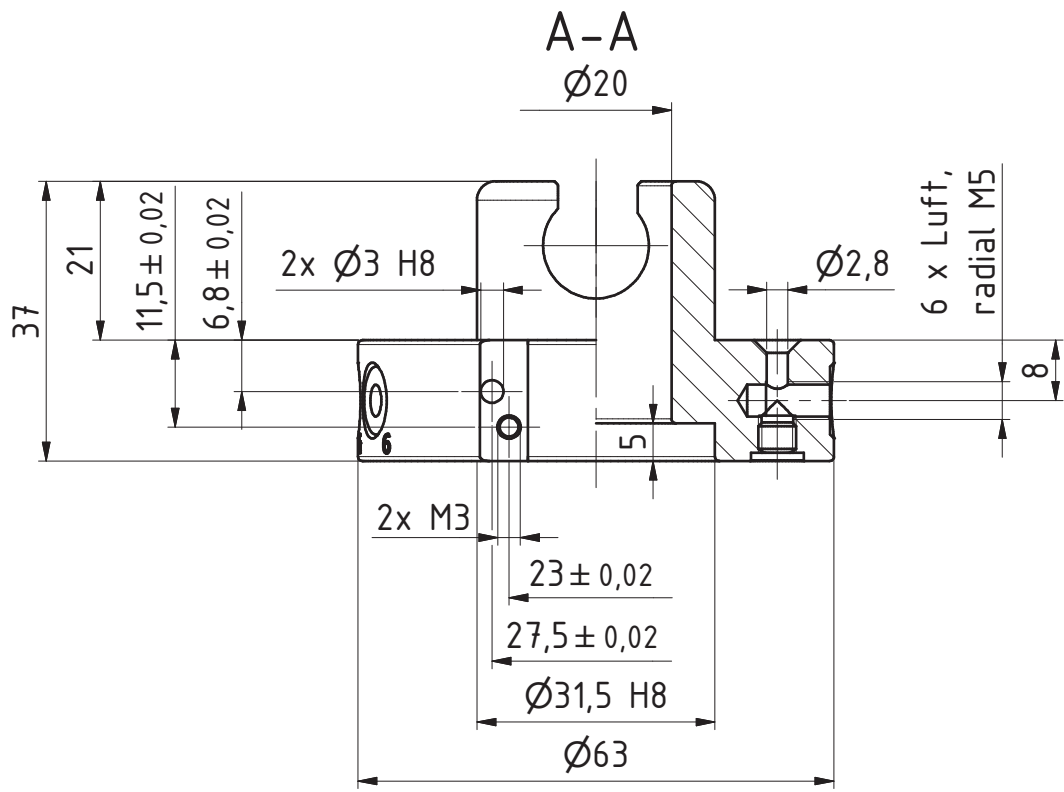

( 1 : 2 )

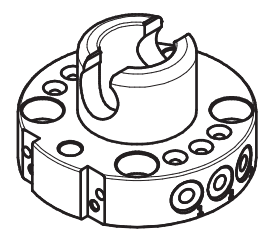

Datum 17.04.2024 Maßstab 1:1

Zeichnungsnummer  
 G-SHS063-U-A050

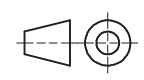

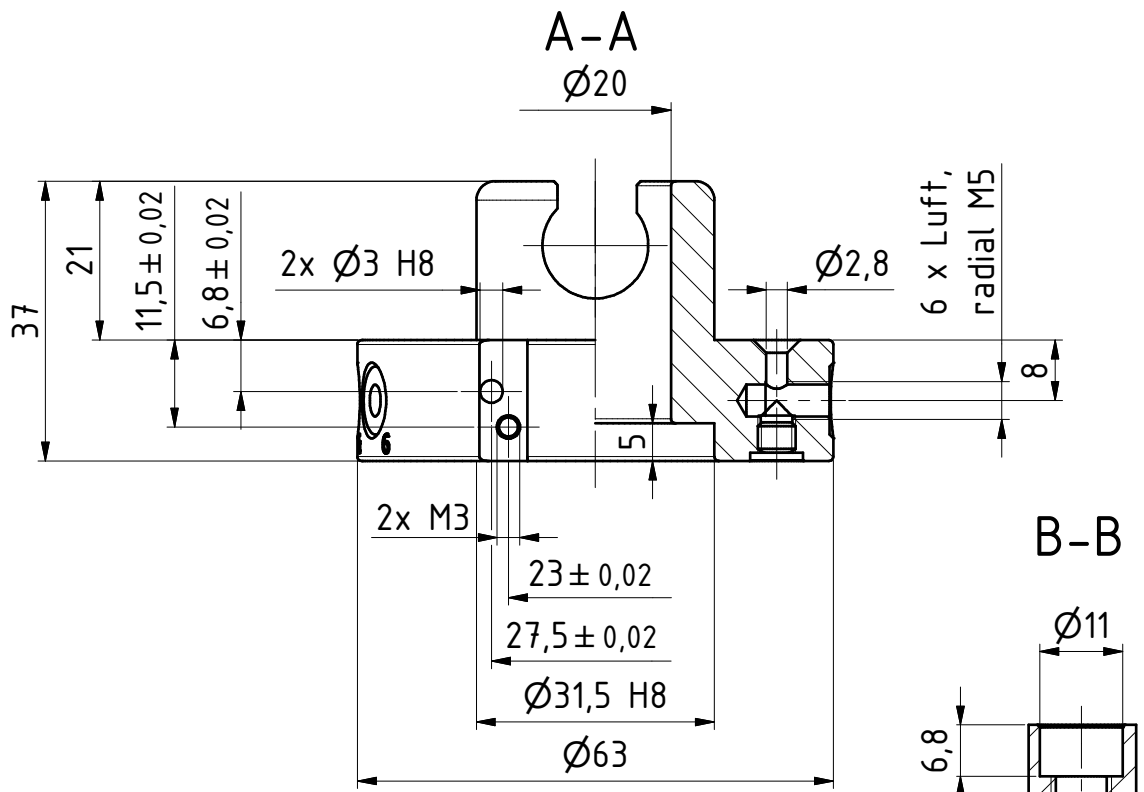

B-B

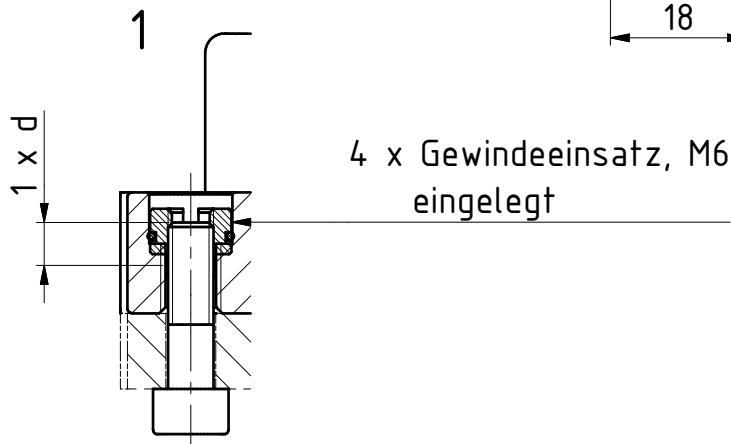
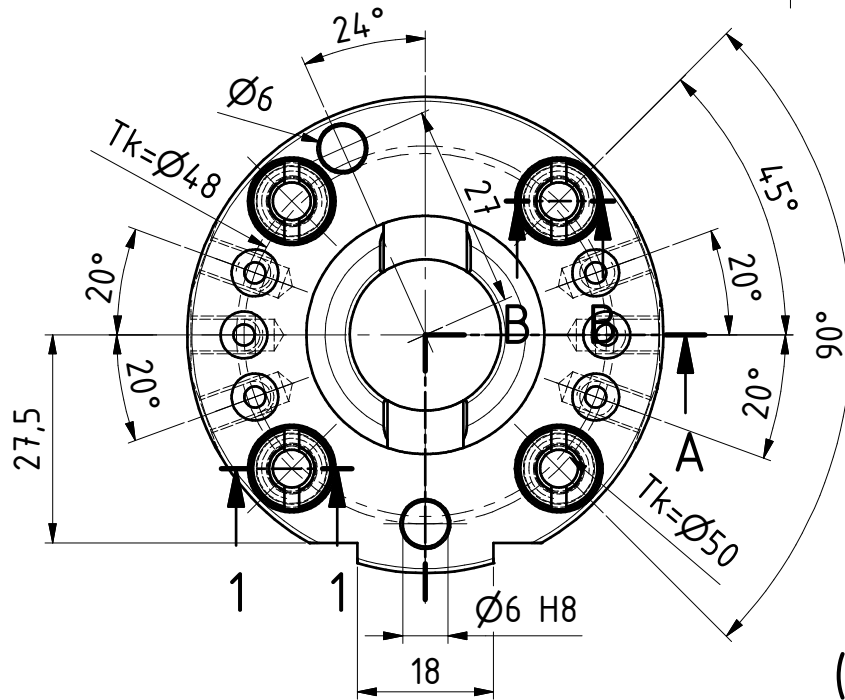
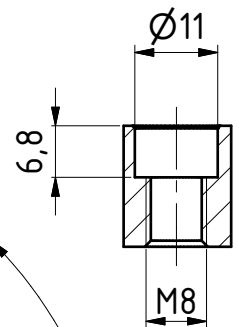

( 1 : 2 )

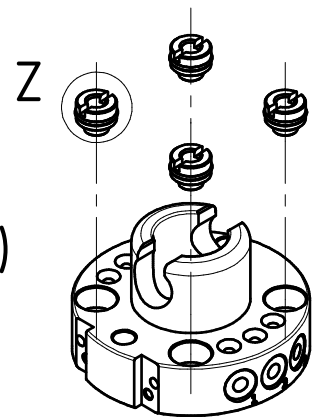

Z ( 1 : 1 )



Datum 17.04.2024

Maßstab 1:1

Zeichnungsnummer

G-SHS063-U-A050-M6

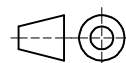

**GRIP**  
GRIP GmbH Handhabungstechnik