

GRIP: G-SHS050
 Oberteil: G-SHS050-O-K040
 Unterteil: G-SHS050-U-A040

S: SHS040
 Kopf: SHK-040-000-000
 Adapter: SHA-040-000-000

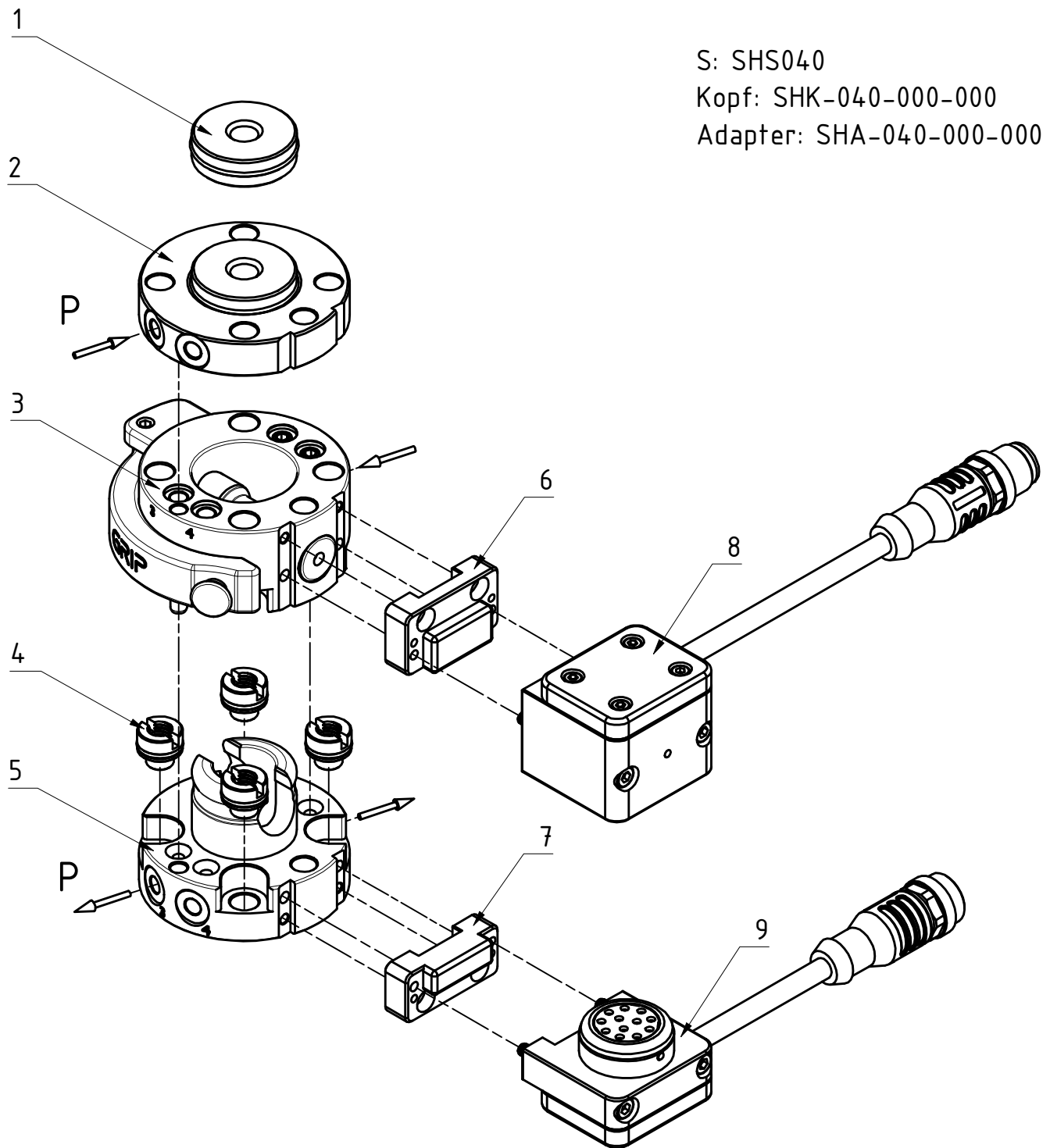

Pos.	GRIP Art.-Nr.	Beschreibung
1	G-ZS050-1	Zentrierscheibe, Al, eloxiert
2	G-ZS050-S2P	Pneumatikflansch inkl. G-ZS050-1
3	G-SHS050-O-K040	Oberteil, Kopf, TK=40
4	ZG-GE-M6	Gewindeeinsatz M6, VA (50, 63, 80)
5	G-SHS050-U-A040	Unterteil, Adapter, TK=40
6	ZG-AP-SEK100-SHS050-O	Adapterplatte, Oberteil, für SEK100
7	ZG-AP-SEK100-SHS050-U	Adapterplatte, Unterteil, für SEK100
8	G-SEK100-O-1E12-300-M12	SEK100 Oberteil
9	G-SEK100-U-1E12-300-M12	SEK100 Unterteil

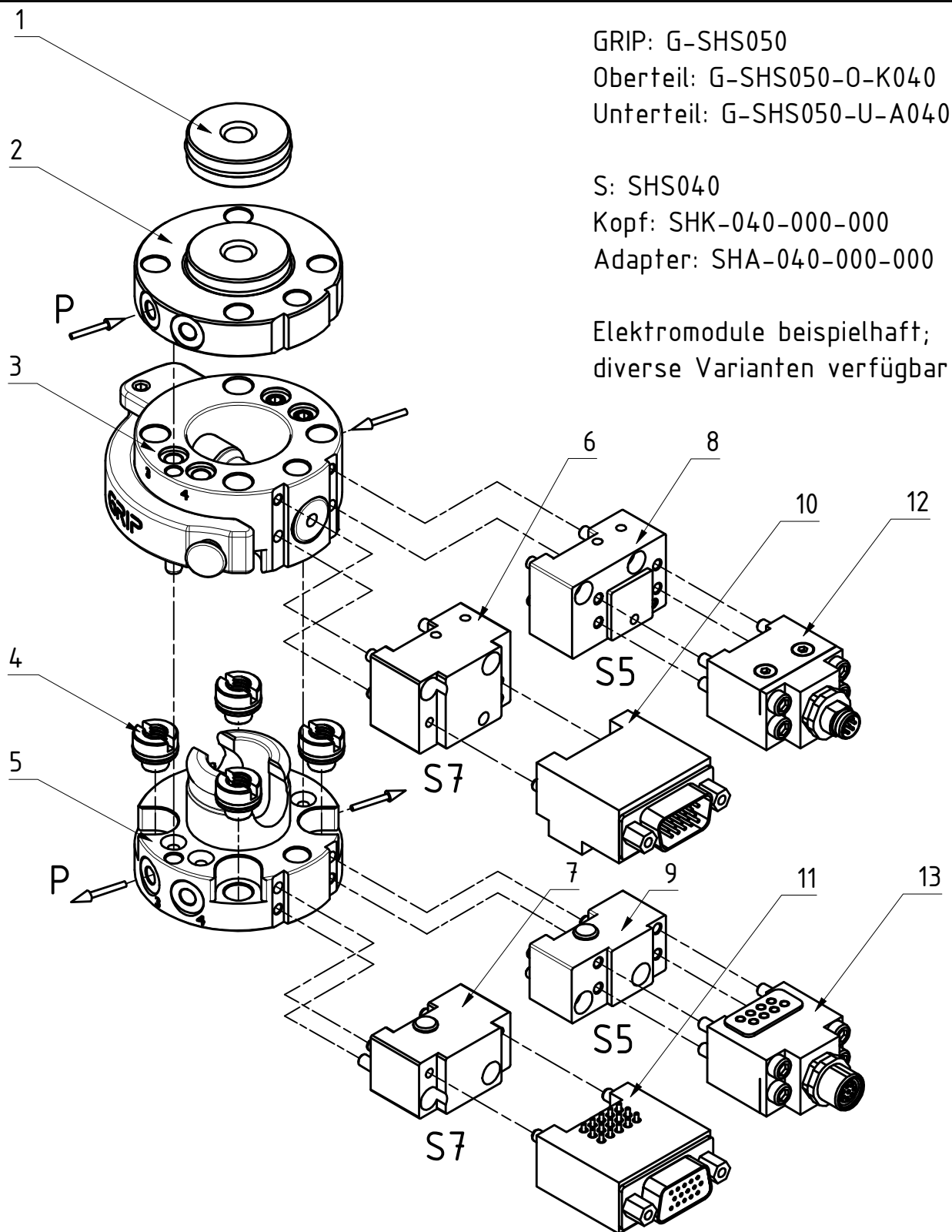

GRIP: G-SHS050
 Oberteil: G-SHS050-O-K040
 Unterteil: G-SHS050-U-A040

S: SHS040
 Kopf: SHK-040-000-000
 Adapter: SHA-040-000-000

Elektromodule beispielhaft;
 diverse Varianten verfügbar

Pos.	GRIP Art.-Nr.	Beschreibung	S Art.-Nr.	S ID
1	G-ZS050-1	Zentrierscheibe, Al, eloxiert	A-HWK-040-BOSS	0302742
2	G-ZS050-S2P	Pneumatikflansch inkl. G-ZS050-1	A-SHK-040-P-RADIAL	1391534
3	G-SHS050-O-K040	Oberteil, Kopf, TK=40	SHK-040-000-000	0310400
4	ZG-GE-M6	Gewindeeinsatz M6, VA (50, 63, 80)		
5	G-SHS050-U-A040	Unterteil, Adapter, TK=40	SHA-040-000-000	0310401
6	ZG-SHS050-O-K040-S7	Adapterplatte K040-S7	SHK-040-AKO-S7	1304690
7	ZG-SHS050-U-A040-S7	Adapterplatte A040-S7	SHA-040-AKO-S7	1304691
8	ZG-SHS050-O-K040-S5	Adapterplatte K040-S5	SHK-040-AKO-S5	1304684
9	ZG-SHS050-U-A040-S5	Adapterplatte A040-S5	SHA-040-AKO-S5	1304688
10	G-SWO-A15-K	A15 Elektromodul, Kopf	SWO-A15-K	9936357
11	G-SWO-A15-A	A15 Elektromodul, Adapter	SWO-A15-A	9936356
12	G-SWO-EM8-005-K	M8-005 Elektromodul, Kopf	SWO-EM8-005-K	9966150
13	G-SWO-EM8-005-A	M8-005 Elektromodul, Adapter	SWO-EM8-005-A	9966151

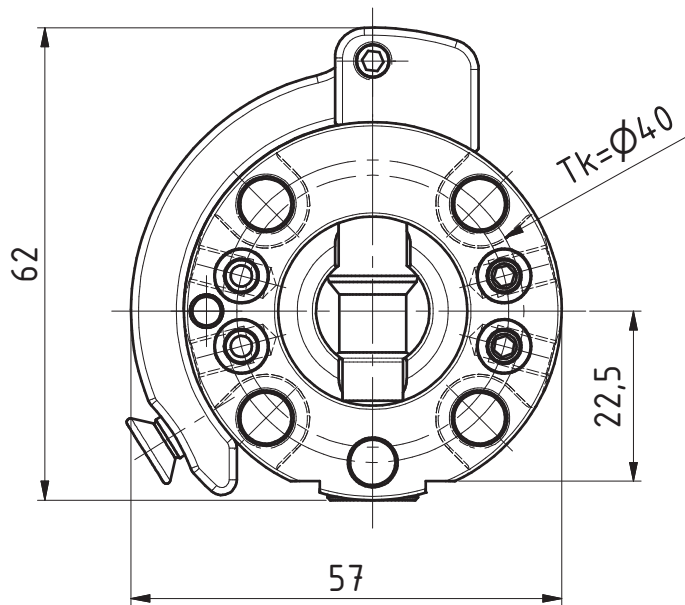
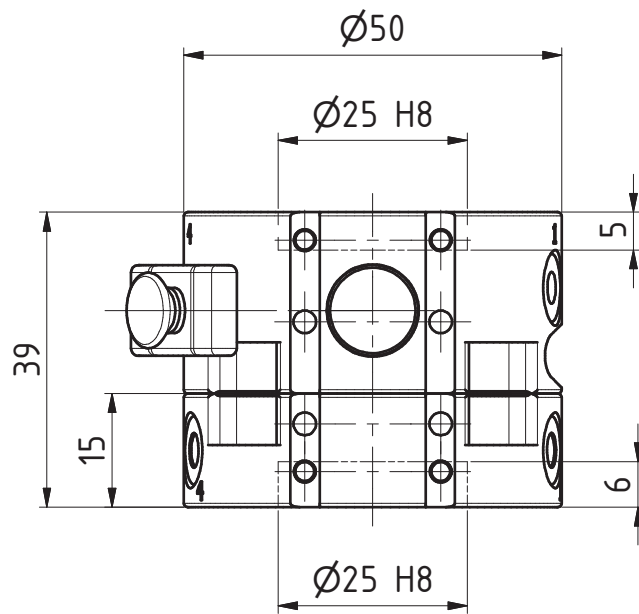

(1 : 2)

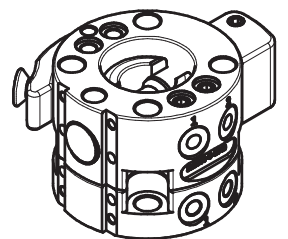

Datum 17.04.2024

Maßstab 1:1

Zeichnungsnummer

G-SHS050-2ZEP

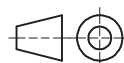

GRIP
GRIP GmbH Handhabungstechnik

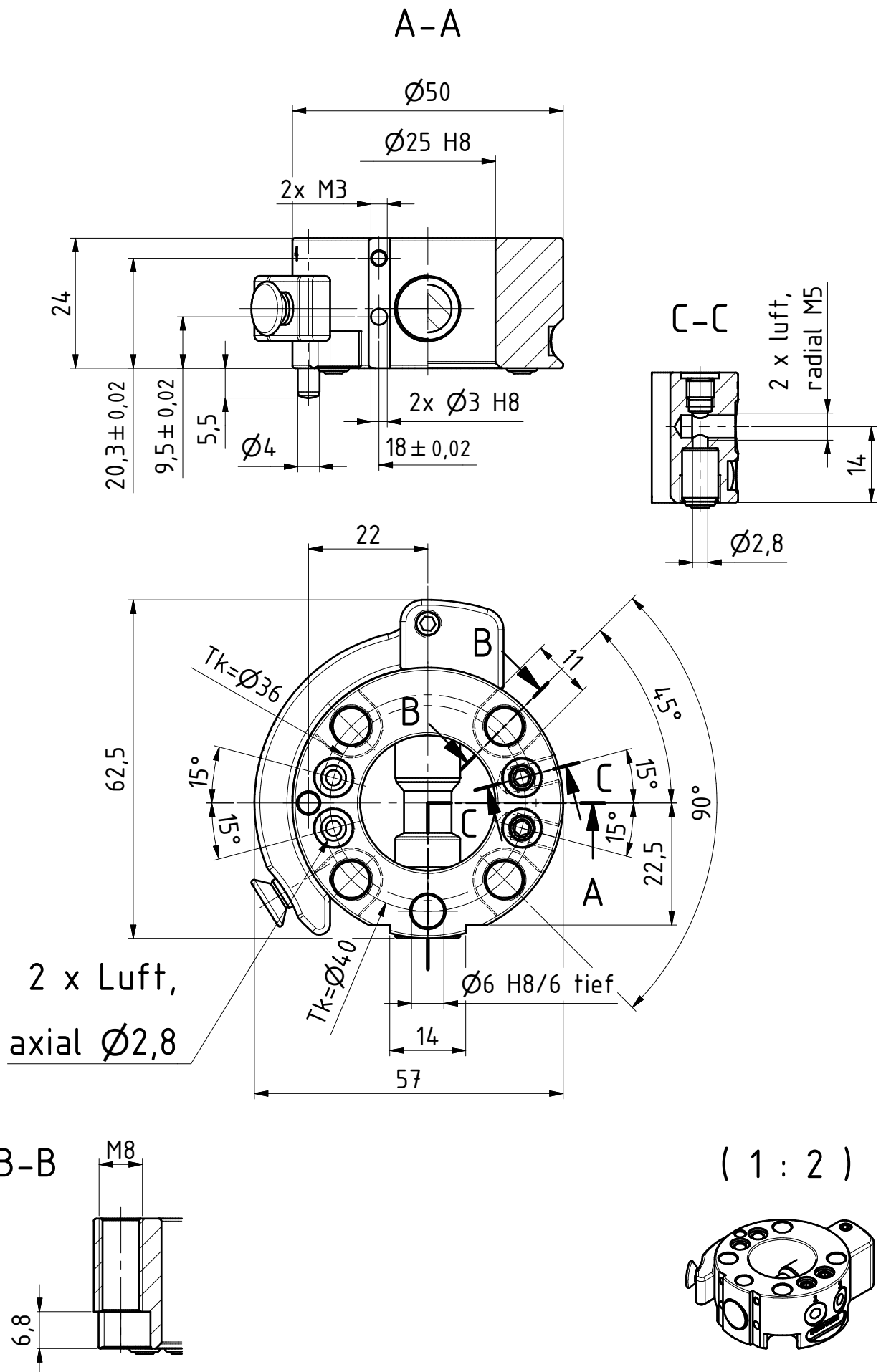

Datum 17.04.2024

Maßstab 1:1

Zeichnungsnummer

G-SHS050-0-K040

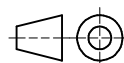

GRIP
GRIP GmbH Handhabungstechnik

A-A

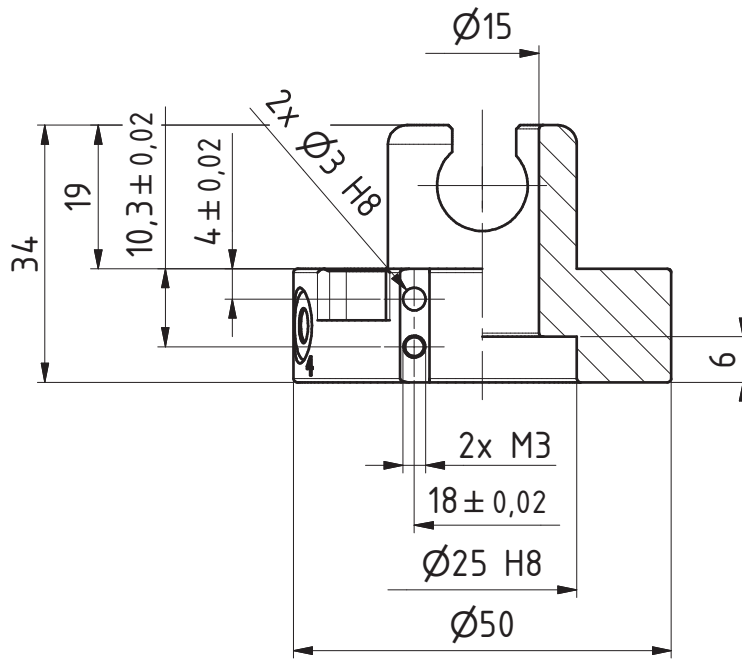

B-B

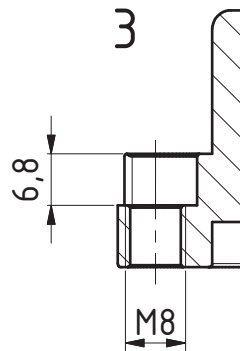
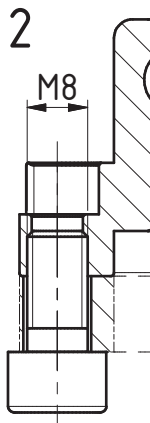
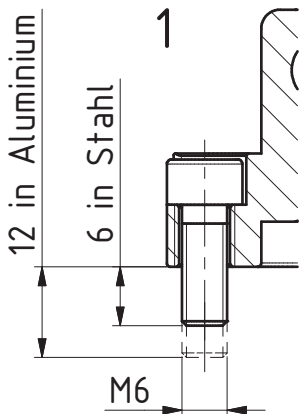
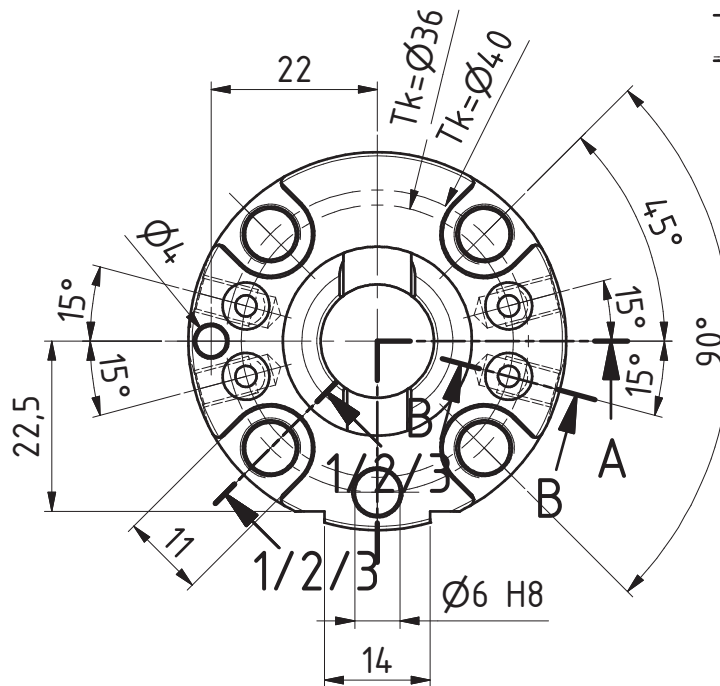
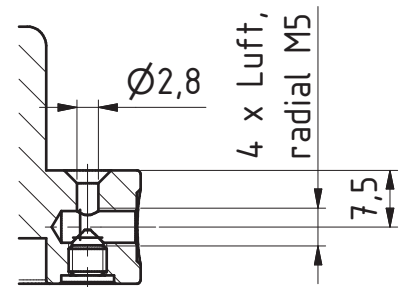

(1 : 2)

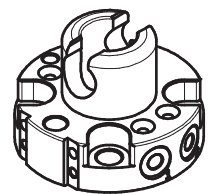

Datum 17.04.2024

Maßstab 1:1

Zeichnungsnummer

G-SHS050-U-A040

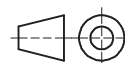

GRIP
GRIP GmbH Handhabungstechnik